



Visualisation; Diagnostics

Easy to Configure

Programming IEC 61131-3

Rapid Installation

PNOZ m EF SafetyNET

PILZ

THE SPIRIT OF SAFETY

- ▶ Configurable, safe small controllers PNOZmulti 2

This document is the original document.

All rights to this documentation are reserved by Pilz GmbH & Co. KG. Copies may be made for the user's internal purposes. Suggestions and comments for improving this documentation will be gratefully received.

Source code from third-party manufacturers or open source software has been used for some components. The relevant licence information is available on the Internet on the Pilz homepage.

Pilz®, PIT®, PMI®, PNOZ®, Primo®, PSEN®, PSS®, PVIS®, SafetyBUS p®, SafetyEYE®, SafetyNET p®, the spirit of safety® are registered and protected trademarks of Pilz GmbH & Co. KG in some countries.



SD means Secure Digital

1	Introduction	5
1.1	Validity of documentation	5
1.2	Using the documentation	5
1.3	Definition of symbols	5
2	Overview	7
2.1	Scope of supply	7
2.2	Unit features	7
2.3	Front view	8
3	Safety	9
3.1	Intended use	9
3.2	System requirements	9
3.3	Safety regulations	10
3.3.1	Safety assessment	10
3.3.2	Use of qualified personnel	10
3.3.3	Warranty and liability	10
3.3.4	Disposal	10
3.3.5	For your safety	11
4	Function Description	12
4.1	Integrated protection mechanisms	12
4.2	Functions	12
4.3	System reaction time	13
4.4	Block diagram	13
5	Installation	14
5.1	General installation guidelines	14
5.2	Mounting distances	14
5.3	Dimensions in mm	15
5.4	Connect the base unit and expansion modules	15
6	Commissioning	17
6.1	General wiring guidelines	17
6.2	Connecting the supply voltage	17
6.3	Interface assignment	18
6.4	Connect SafetyNET p subscribers	18
6.5	Download modified project to the PNOZmulti system	20
7	Operation	21
7.1	LED indicators	21
7.2	Diagnostics and behaviour in case of an error	22
8	Technical details	23
8.1	Safety characteristic data	25
9	Order reference	26
9.1	Product	26

9.2 Accessories 26

1 Introduction

1.1 Validity of documentation

This documentation is valid for the product PNOZ m EF SafetyNET from Version HW:02, FW:01.01.

This operating manual explains the function and operation, describes the installation and provides guidelines on how to connect the product.

1.2 Using the documentation

This document is intended for instruction. Only install and commission the product if you have read and understood this document. The document should be retained for future reference.

1.3 Definition of symbols

Information that is particularly important is identified as follows:



DANGER!

This warning must be heeded! It warns of a hazardous situation that poses an immediate threat of serious injury and death and indicates preventive measures that can be taken.



WARNING!

This warning must be heeded! It warns of a hazardous situation that could lead to serious injury and death and indicates preventive measures that can be taken.



CAUTION!

This refers to a hazard that can lead to a less serious or minor injury plus material damage, and also provides information on preventive measures that can be taken.



NOTICE

This describes a situation in which the product or devices could be damaged and also provides information on preventive measures that can be taken. It also highlights areas within the text that are of particular importance.



INFORMATION

This gives advice on applications and provides information on special features.

2 Overview

2.1 Scope of supply

- ▶ Expansion module PNOZ m EF SafetyNET
- ▶ Jumper

2.2 Unit features

Application of the product PNOZ m EF SafetyNET:

Expansion module for safe data exchange between SafetyNET p subscribers via SafetyNET p RTFL.

The product has the following features:

- ▶ Can be configured in the PNOZmulti Configurator
- ▶ RTFL (Real Time Frame Line) communication for applications with high real-time requirements
- ▶ In PNOZmulti Configurator up to 128 virtual inputs and 32 virtual outputs can be defined for safe communication via SafetyNET p.
- ▶ Every PNOZmulti 2 SafetyNET p subscriber (base unit PNOZmulti 2) is assigned a module PNOZ m EF SafetyNET.
- ▶ Up to 16 SafetyNET p subscribers can be connected in a line structure.
- ▶ The module PNOZ m EF SafetyNET is connected as the first safe module to the left of the base unit.
- ▶ LED display for communication via SafetyNET p and for displaying errors.
- ▶ Plug-in connection terminals:
Either spring-loaded terminal or screw terminal available as an accessory (see Order references for accessories).
- ▶ Please refer to the document "PNOZmulti System Expansion" for details of the base units PNOZmulti 2 that can be connected.

2.3 Front view

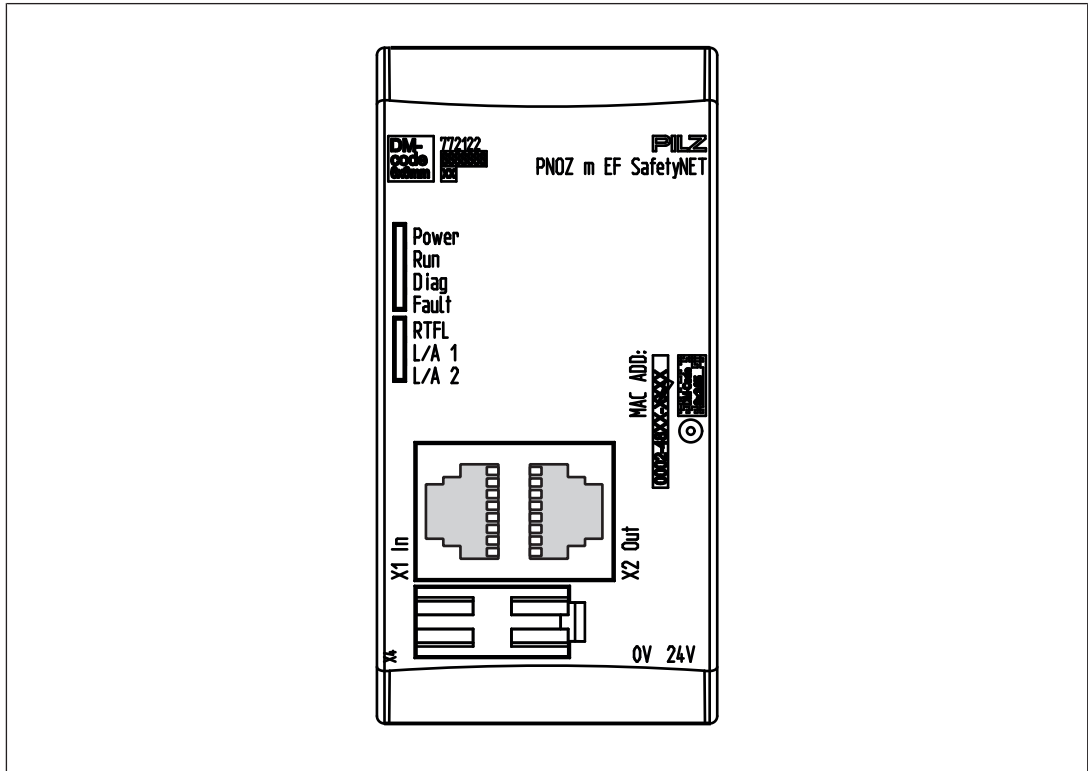

Legend

X1 In:	SafetyNET p input
X2 Out:	SafetyNET p output
0 V, 24 V:	Supply connections
LEDs:	Power, Run, Diag, Fault, RTFL, L/A 1, L/A 2

To determine the version of the device, please note:

The firmware version number is on the labelling clip. This is also the version number that must be selected in the PNOZmulti Configurator under **Version** during the hardware configuration.

3 Safety

3.1 Intended use

The expansion module is used for safe communication between SafetyNET p subscribers via SafetyNET p RTFL.

The expansion module may only be connected to a base unit from the configurable system PNOZmulti 2 (please refer to the document "PNOZmulti System Expansion" for details of the base units that can be connected).

The configurable small control systems PNOZmulti are used for the safety-related interruption of safety circuits and are designed for use in:

- ▶ E-STOP equipment
- ▶ Safety circuits in accordance with VDE 0113 Part 1 and EN 60204-1
- ▶ The product PNOZ m EF SafetyNET meets the requirements of the standards EN 81-20, EN 81-22 and EN 81-50, harmonised under the Lifts Directive 2014/33/EU, and the requirements of the standard EN 115-1, harmonised under the Machinery Directive 2006/42/EC.
- ▶ The programmable safety system should be installed in a protected environment that meets at least the requirements of pollution degree 2.
Example: Protected inside space or control cabinet with protection type IP54 and corresponding air conditioning.

The following is deemed improper use in particular

- ▶ Any component, technical or electrical modification to the product,
- ▶ Use of the product outside the areas described in this manual,
- ▶ Use of the product outside the technical details (see [Technical details](#)  23).



NOTICE

EMC-compliant electrical installation

The product is designed for use in an industrial environment. The product may cause interference if installed in other environments. If installed in other environments, measures should be taken to comply with the applicable standards and directives for the respective installation site with regard to interference.

3.2 System requirements

Please refer to the "Product Modifications PNOZmulti" document in the "Version overview" section for details of which versions of the base unit and PNOZmulti Configurator can be used for this product.

3.3 Safety regulations

3.3.1 Safety assessment

Before using a device it is necessary to perform a safety assessment in accordance with the Machinery Directive.

Functional safety is guaranteed for the product as a single component. However, this does not guarantee the functional safety of the overall plant/machine. In order to achieve the required safety level for the overall plant/machine, define the safety requirements for the plant/machine and then define how these must be implemented from a technical and organisational standpoint.

3.3.2 Use of qualified personnel

The products may only be assembled, installed, programmed, commissioned, operated, maintained and decommissioned by competent persons.

A competent person is someone who, because of their training, experience and current professional activity, has the specialist knowledge required to test, assess and operate the work equipment, devices, systems, plant and machinery in accordance with the general standards and guidelines for safety technology.

It is the company's responsibility only to employ personnel who

- ▶ Are familiar with the basic regulations concerning health and safety / accident prevention,
- ▶ Have read and understood the information provided in this description under "Safety",
- ▶ And have a good knowledge of the generic and specialist standards applicable to the specific application.

3.3.3 Warranty and liability

All claims to warranty and liability will be rendered invalid if

- ▶ The product was used contrary to the purpose for which it is intended,
- ▶ Damage can be attributed to not having followed the guidelines in the manual,
- ▶ Operating personnel are not suitably qualified,
- ▶ Any type of modification has been made (e.g. exchanging components on the PCB boards, soldering work etc.).

3.3.4 Disposal

- ▶ In safety-related applications, please comply with the mission time T_M in the safety-related characteristic data.
- ▶ When decommissioning, please comply with local regulations regarding the disposal of electronic devices (e.g. Electrical and Electronic Equipment Act).

3.3.5 For your safety

The unit meets all the necessary conditions for safe operation. However, you should always ensure that the following safety requirements are met:

- ▶ This operating manual only describes the basic functions of the unit. The expanded functions are described in the PNOZmulti Configurator's online help. Only use these functions once you have read and understood the documentations.
- ▶ Do not open the housing or make any unauthorised modifications.
- ▶ Please make sure you shut down the supply voltage when performing maintenance work (e.g. exchanging contactors).

4 Function Description

4.1 Integrated protection mechanisms

The relay meets the following safety requirements:

- ▶ The circuit is redundant with built-in self-monitoring.
- ▶ The safety device remains effective in the case of a component failure.

4.2 Functions

The expansion module PNOZ m EF SafetyNET is used for safe data exchange between several SafetyNET p subscribers via SafetyNET p RTFL.

The safe virtual inputs and outputs that are defined via SafetyNET p are selected and configured for each PNOZmulti 2 system in PNOZmulti Configurator. Inputs and outputs are assigned to the SafetyNET p subscribers in the software tool PNOZmulti Network Editor.

The LEDs on the base unit and expansion modules indicate the status of the configurable control system PNOZmulti 2.

You can find a description of the configuration in the PNOZmulti Configurator online help and in the PNOZmulti Network Editor online help.

Data exchange:

Communication can start when all the configured SafetyNET p subscribers are available.

Communication is ended when a SafetyNET p subscriber ends its participation (is in stop state).

- ▶ Data is exchanged cyclically
- ▶ After the end of a PNOZmulti 2 cycle, each PNOZmulti 2 base unit sends its output data to the module PNOZ m EF SafetyNET.
- ▶ Within the next cycle, the output data are transferred to all the participating modules PNOZ m EF SafetyNET.
- ▶ At the beginning of a cycle of PNOZmulti 2 each base unit requests its input data from the module PNOZ m EF SafetyNET an.

SafetyNET p network:

Every PNOZmulti 2 base unit is assigned an expansion module PNOZ m EF SafetyNET. Up to 16 SafetyNET p subscribers can be connected via SafetyNET p in a line structure.

The SafetyNET p subscribers are interconnected in a linear topology. That is, all the SafetyNET p subscribers are combined without branches. However, the wiring sequence has no influence on communication.

Virtual inputs and outputs:

For each module, 32 safe outputs and 128 safe inputs can be defined. Inputs and outputs to the communicating SafetyNET p subscribers are assigned in the PNOZmulti Network Editor.

4.3 System reaction time

Calculation of the maximum reaction time between an input switching off and a linked output in the system switching off is described in the document "PNOZmulti System Expansion".

4.4 Block diagram

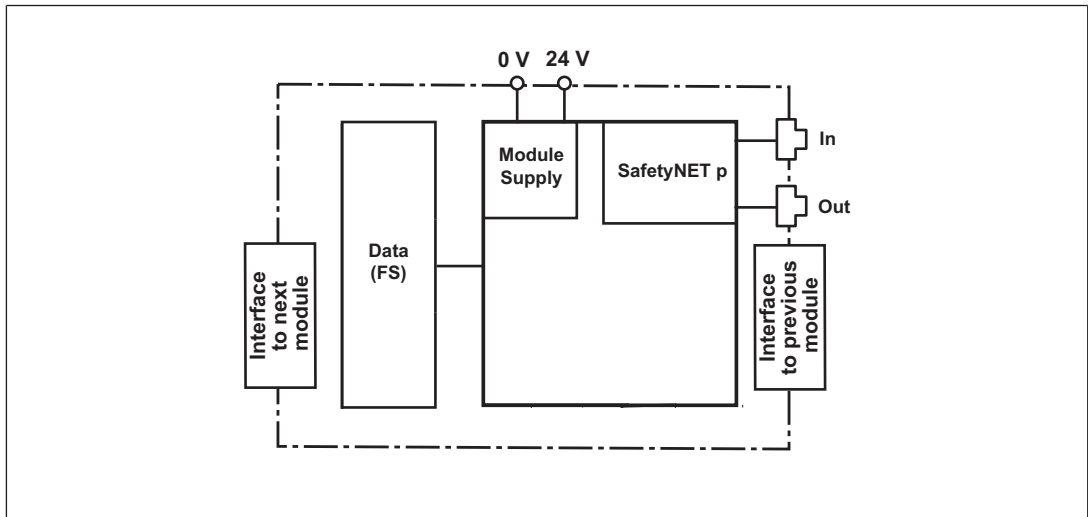

5 Installation

5.1 General installation guidelines

- ▶ The unit should be installed in a control cabinet with a protection type of at least IP54.
- ▶ Fit the safety system to a horizontal mounting rail. The venting slots must face upward and downward. Other mounting positions could damage the safety system.
- ▶ Use the locking elements on the rear of the unit to attach it to a mounting rail.
- ▶ In environments exposed to heavy vibration, the unit should be secured using a fixing element (e.g. retaining bracket or end angle).
- ▶ Open the locking slide before lifting the unit from the mounting rail.
- ▶ To comply with EMC requirements, the mounting rail must have a low impedance connection to the control cabinet housing.
- ▶ The ambient temperature of the PNOZmulti units in the control cabinet must not exceed the figure stated in the technical details. Air conditioning may otherwise be required.



NOTICE

Damage due to electrostatic discharge!

Electrostatic discharge can damage components. Ensure against discharge before touching the product, e.g. by touching an earthed, conductive surface or by wearing an earthed armband.

5.2 Mounting distances

With control cabinet installation it is essential to maintain a certain distance from the top and bottom, as well as to other heat-producing devices (see diagram). The values stated for the mounting distances are minimum specifications.

The ambient temperature in the control cabinet must not exceed the figure stated in the technical details. Air conditioning may otherwise be required.

Mounting distances:

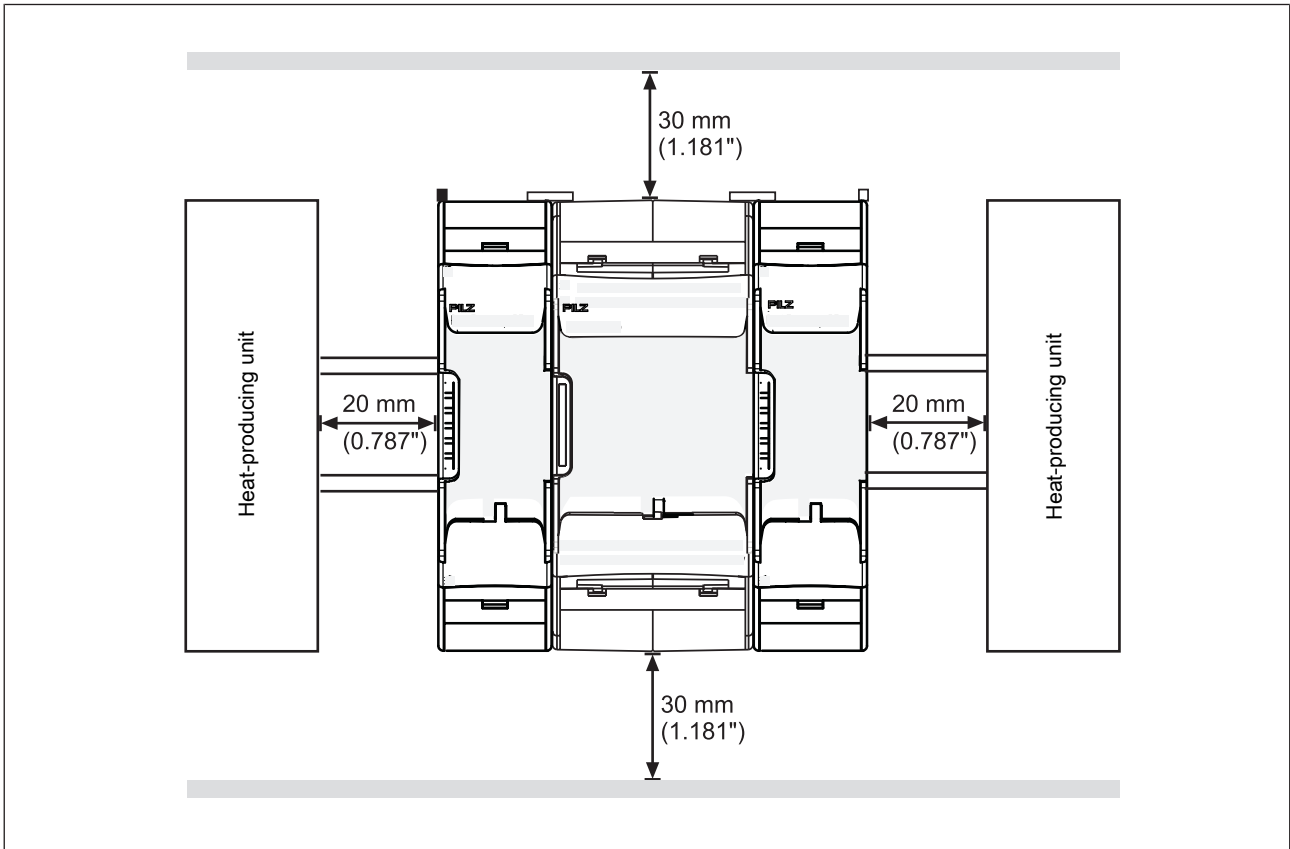

5.3 Dimensions in mm

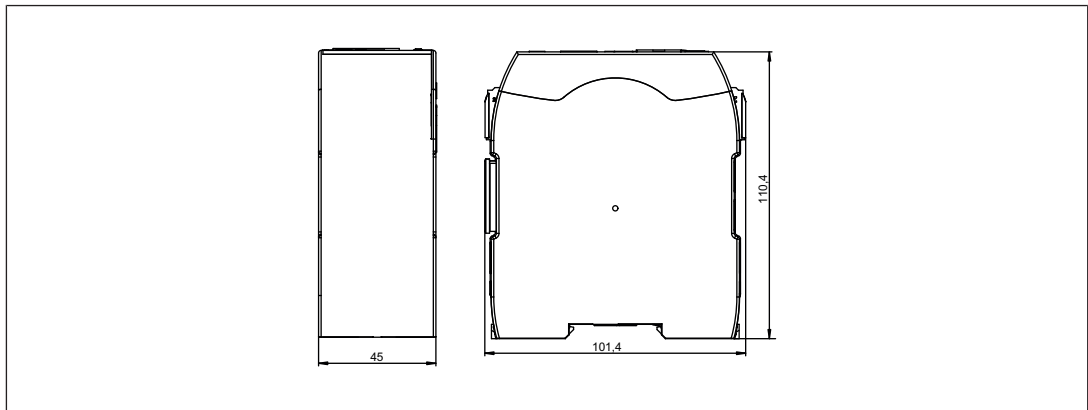

5.4 Connect the base unit and expansion modules

Connect the base unit and the expansion module as described in the operating instructions for the base units.

- ▶ Connect the black/yellow terminator to the expansion module.
- ▶ Install the expansion module in the position in which it is configured in the PNOZmulti Configurator.

The position of the expansion modules is defined in the PNOZmulti Configurator. The expansion modules are connected to the left or right of the base unit, depending on the type. Please refer to the document "PNOZmulti System Expansion" for details of the number of modules that can be connected to the base unit and the module types.

6 Commissioning

6.1 General wiring guidelines

The wiring is defined in the PNOZmulti Configurator user program.

Please note:

- ▶ Information given in the "[Technical details \[📖 23\]](#)" must be followed.
- ▶ Use copper wiring with a temperature stability of 75 °C.
- ▶ The following minimum requirements of the connection cable and connector must be met:
 - Only use standard industrial Ethernet cable and connectors.
 - Only use double-shielded twisted pair cable and shielded RJ45 connectors (industrial connectors).
 - 100BaseTX cable in accordance with the Ethernet standard (min. category 5)
 - Use only straight through cables. Do not use crossover cables.
- ▶ The max. cable length between two modules may be max. 100 m.
- ▶ The power supply must meet the regulations for extra low voltages with safe separation (SELV, PELV).



CAUTION!

Only connect and disconnect the expansion module when the supply voltage is switched off.

6.2 Connecting the supply voltage

Connect the supply voltage to the fieldbus module:

- ▶ **24 V** terminal: + 24 VDC
- ▶ **0 V** terminal: 0 V
- ▶ Protect the supply voltage as follows:
 - Circuit breaker, characteristic C - 6 A
 - or
 - Blow-out fuse, slow, 6A

6.3 Interface assignment

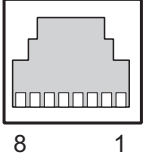
RJ45 socket 8-pin	PIN	Standard
	1	TD+ (Transmit+)
	2	TD- (Transmit-)
	3	RD+ (Receive+)
	4	n.c.
	5	n.c.
	6	RD- (Receive-)
	7	n.c.
	8	n.c.

n.c.: Not connected

6.4 Connect SafetyNET p subscribers

The SafetyNET p subscribers are networked in a linear topology. That is, all the SafetyNET p subscribers are combined without branches. To connect the SafetyNET p subscribers, proceed as follows:

- ▶ The X2 Out- interface of a SafetyNET p subscriber always has to be connected to the X1 In interface of the subscriber following in the line.
Please note: The interfaces X2 Out and X1-In have no switch function.
- ▶ The X1 In interface of the first SafetyNET p subscriber and the X2 Out interface of the last SafetyNET p subscriber remain free.

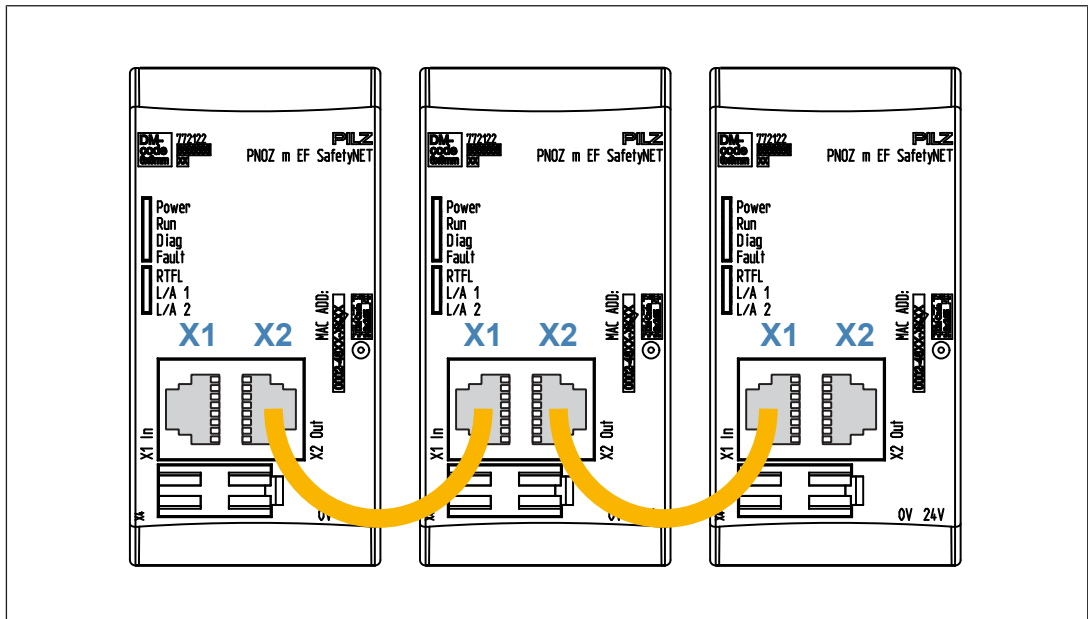

- ▶ The SafetyNET p subscribers can be connected in the SafetyNET p line in any sequence when all the PNOZmulti SafetyNET p subscribers have the same version. This has no influence on communication.



NOTICE

Please note when using modules PNOZ m EF SafetyNET with different versions:

When using PNOZ m EF SafetyNET of version HW:01, FW:01.00 together with modules of version HW:02, FW:01.01 in a SafetyNET p line, the first connected module must always be a module with version HW:01, FW:01.00.

Otherwise, there is no stable communication.

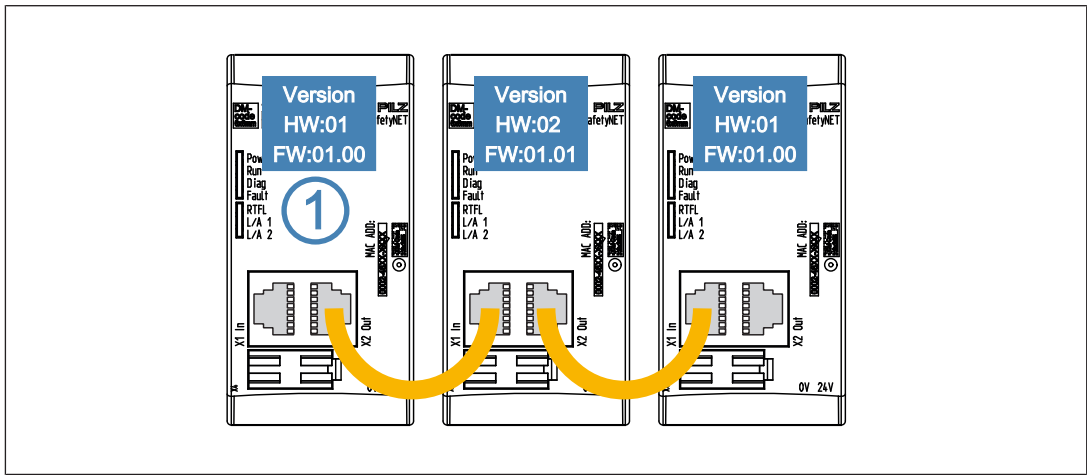

Fig.: SafetyNET p line with different versions of PNOZ m EF SafetyNET.

- ▶ Up to 16 SafetyNET p subscribers can be connected in a line structure.
- ▶ The SafetyNET p subscribers must be connected directly. No Ethernet switch must be interposed.

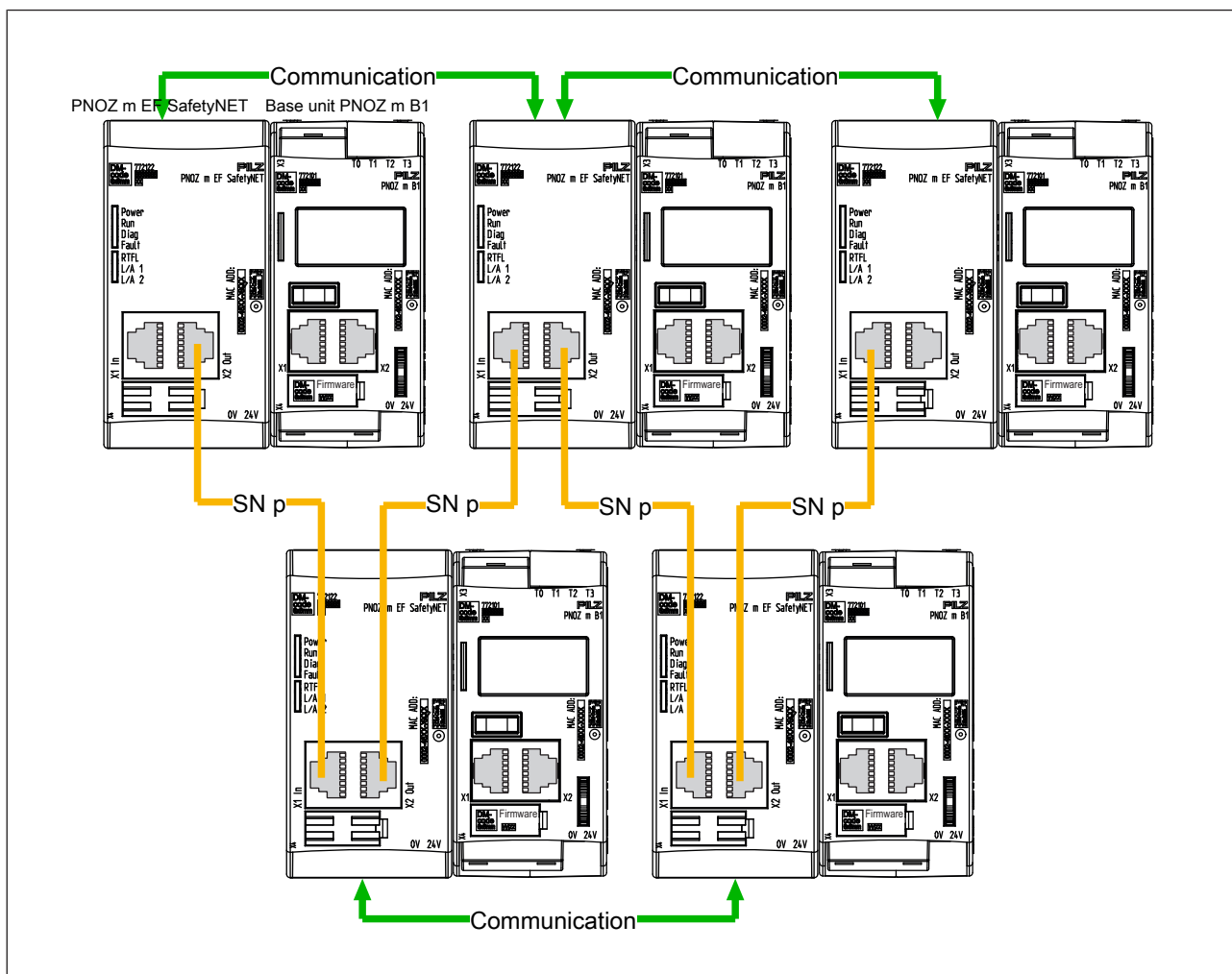

Fig.: SafetyNET p line with 5 SafetyNET p subscribers

6.5 Download modified project to the PNOZmulti system

As soon as an additional expansion module has been connected to the system, the project must be amended using the PNOZmulti Configurator. Proceed as described in the operating instructions for the base unit.

Changes to the SafetyNET p connection have to be adapted in the software tool PNOZmulti Network Editor.



NOTICE

For the commissioning and after every program change, you must check whether the safety devices are functioning correctly.





7 Operation













































When the supply voltage is switched on, the PNOZmulti safety system copies the configuration from the chip card or USB memory.

The LEDs “POWER”, “DIAG”, “FAULT”, “IFFAULT” and “OFAULT” will light up on the base unit.

7.1 LED indicators

Legend

-  LED on
-  LED flashes
-  LED flashes 1x
-  LED off

LEDs							Description
Power	Run	Diag	Fault	RTFL	L/A 1	L/A 2	
							Supply voltage is present.
							Supply voltage is not present.
							Module runs error-free.
							The module is in stop state.
							The module is in operational state.
							The module is in pre-operational state.
							Periphery error. Module continues to run.
							Periphery error. The module is in stop state (safe state).
							Internal module error. Contact Pilz.
							Ethernet connection available at X1.
							No Ethernet connection available at X1.
							Ethernet connection available at X2.
							No Ethernet connection available at X2.
							SafetyNET p RTFL connection has been established.
							No data connection via SafetyNET p RTFL.
							The module is reached by the bus master when establishing the SafetyNET p RTFL connection.
							All subscribers are synchronised when establishing the SafetyNET p RTFL connection.

7.2 Diagnostics and behaviour in case of an error

Each base unit contains information about

- ▶ The state of its SafetyNET p receive connections (inputs of all devices from which it is received).
- ▶ The connection state of the Ethernet interface X1 In and X2 Out of the own SafetyNET p module (helpful when checking the cabling of the SafetyNET p subscribers).
- ▶ The role of the own SafetyNET p module within a SafetyNET p line topology (bus master or subscriber).

When the receive connection is interrupted, the base units switch the virtual inputs to "0".

The output data continue to be transferred via SafetyNET p.

The base unit remains in a RUN condition.

Bus master

During configuration of a SafetyNET p RTFL network, exactly one subscriber is always assigned the role of the bus master. The assignment is automatic when creating the SafetyNET p project.

Via the base unit, it can be evaluated what subscribers were assigned the role of bus master.

The subscriber with the role of bus master may be connected at each position of the SafetyNET p line, just as other subscribers.

This specific subscriber provides the following additional information to the base unit:

- ▶ Whether the number of configured SafetyNET p modules matches the number of connected SafetyNET p modules.
- ▶ Whether the device address of the configured SafetyNET p modules matches the device address of the connected SafetyNET p modules.

8 Technical details

General	
Certifications	CE, EAC (Eurasian), TÜV
Application range	Failsafe
Electrical data	
Supply voltage	
for	Module supply
Voltage	24 V
Kind	DC
Voltage tolerance	-20 %/+25 %
Max. continuous current that the external power supply must provide	130 mA
Output of external power supply (DC)	3,2 W
Potential isolation	yes
Supply voltage	
for	Module supply
internal	Via base unit
Voltage	3,3 V
Kind	DC
Current consumption	60 mA
Power consumption	0,2 W
Max. power dissipation of module	3,5 W
Status indicator	LED
Fieldbus interface	
Fieldbus interface	SafetyNET p
Device type	Device
Connection	2 x RJ45
Galvanic isolation	yes
Environmental data	
Ambient temperature	
In accordance with the standard	EN 60068-2-14
Temperature range	0 - 60 °C
Forced convection in control cabinet off	55 °C
Storage temperature	
In accordance with the standard	EN 60068-2-1/-2
Temperature range	-25 - 70 °C
Climatic suitability	
In accordance with the standard	EN 60068-2-30, EN 60068-2-78
Humidity	93 % r. h. at 40 °C
Condensation during operation	Not permitted
Max. operating height above sea level	2000 m
EMC	EN 61131-2

Environmental data

Vibration

In accordance with the standard	EN 60068-2-6
Frequency	5 - 150 Hz
Acceleration	1g

Shock stress

In accordance with the standard	EN 60068-2-27
Acceleration	15g
Duration	11 ms

Airgap creepage

In accordance with the standard	EN 61131-2
Overvoltage category	II
Pollution degree	2

Protection type

In accordance with the standard	EN 60529
Housing	IP20
Terminals	IP20
Mounting area (e.g. control cabinet)	IP54

Potential isolation

Potential isolation between	Fieldbus and module voltage
Type of potential isolation	Functional insulation
Rated surge voltage	500 V

Mechanical data

Mounting position	horizontally on mounting rail
-------------------	--------------------------------------

DIN rail

Top hat rail	35 x 7,5 EN 50022
Recess width	27 mm

Material

Bottom	PC
Front	PC
Top	PC

Connection type	Spring-loaded terminal, screw terminal
-----------------	---

Mounting type	plug-in
---------------	----------------

Conductor cross section with screw terminals

1 core flexible	0,25 - 2,5 mm², 24 - 12 AWG
2 core with the same cross section, flexible without crimp connectors or with TWIN crimp connectors	0,2 - 1,5 mm², 24 - 16 AWG

Torque setting with screw terminals	0,5 Nm
-------------------------------------	---------------

Conductor cross section with spring-loaded terminals:

Flexible with/without crimp connector	0,2 - 2,5 mm², 24 - 12 AWG
---------------------------------------	--

Spring-loaded terminals: Terminal points per connection	2
---	----------

Stripping length with spring-loaded terminals	9 mm
---	-------------

Mechanical data

Dimensions

Height **101,4 mm**

Width **45 mm**

Depth **110,4 mm**

Weight **180 g**

Where standards are undated, the 2017-06 latest editions shall apply.

8.1 Safety characteristic data



NOTICE

You must comply with the safety characteristic data in order to achieve the required safety level for your plant/machine.

Operating mode	EN ISO 13849-1: 2015	EN ISO 13849-1: 2015	EN 62061 SIL CL	EN 62061 PFH ₀ [1/h]	IEC 61511 SIL	IEC 61511 PFD	EN ISO 13849-1: 2015
	PL	Category					T _M [year]
–	PL e	Cat. 4	SIL CL 3	1,54E-09	SIL 3	5,66E-05	20

Explanatory notes for the safety-related characteristic data:

- ▶ The SIL CL value in accordance with EN 62061 corresponds to the SIL value in accordance with EN 61508.
- ▶ T_M is the maximum mission time in accordance with EN ISO 13849-1. The value also applies as the retest interval in accordance with EN 61508-6 and IEC 61511 and as the proof test interval and mission time in accordance with EN 62061.

All the units used within a safety function must be considered when calculating the safety characteristic data.



INFORMATION

A safety function's SIL/PL values are **not** identical to the SIL/PL values of the units that are used and may be different. We recommend that you use the PAScal software tool to calculate the safety function's SIL/PL values.

9 Order reference

9.1 Product

Product type	Features	Order no.
PNOZ m EF SafetyNET	Expansion module	772 122

9.2 Accessories

Cable and connector

Product type	Features	Order no.
SafetyNET p Cable	CAT5e, sold by the metre	380 000
RJ45 Connector	8-pin RJ45 male connector, straight, Cat 6a	380 401

Connection terminals and jumper

Product type	Features	Order no.
Spring terminals	Screw terminals, 1 piece	750 017
Spring terminals	Spring-loaded terminals, 1 piece	751 017
Jumper	PNOZ mm0.xp connector left (10 pcs)	779 260